

# «sue+til» residential development, Winterthur

2019

---



«sue+til»: Currently the largest residential development made of wood in Switzerland, it comprises 307 apartments, a mixed-use first floor and 200 parking spaces. The 6-storey building is a showcase project for timber construction in Switzerland.

## The project

Delays in the construction process often have to be expected with major projects of this kind. Not so with «sue+til» in Winterthur. The first tenants were able to move into their apartments six months earlier than planned. Thanks to the innovative solutions and the dry construction method, which is possible with wood, the first tenants were able to move into their apartments 14 months after the start of the erection work. Functional modules with repetitive construction types were developed for the investor project. At the same time, the floor plans are very different and equally attractive for singles, couples, families or pensioners. The development is not only interesting from an architectural and timber construction point of view. It also meets the highest energy standards and complies with the requirements of the 2000-watt society.

## The construction method

The «sue+til» development consists of 80% timber. The storey ceilings and the interior and exterior walls are made of prefabricated elements. Only the staircase and the basement are made of concrete. Thanks to the consistent digital planning and the high degree of prefabrication, «sue+til» in timber construction is more economical than a comparable project in reinforced concrete.

## The challenge

The very fast construction method required consistent prefabrication and precise construction site logistics. This required seamless and error-free planning of all components. Timbatec played its part with the works planning, the fire protection and statics concept and the construction site inspections.



Interior view



Loggia with supports and ceilings in timber construction

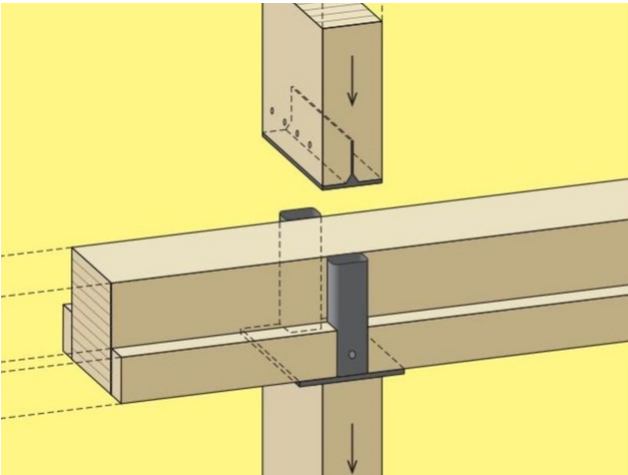

The node: steel parts transfer the load from one support to the next.  
Source: Hochparterre



The node: steel parts transfer the load from one support to the next.  
Source: Hochparterre

### Construction Data

- Building volume 178'888 m<sup>3</sup>
- Floor space 53'280 m<sup>2</sup>
- Solid and glulam timber 6'800 m<sup>3</sup>
- Veneer and multilayer panels 1'130 m<sup>3</sup>

### Construction costs

- BKP 1-9: 162 million Swiss francs
- BKP 214 (assembly construction in wood): 15 million Swiss francs

### Services of Timbatec

- SIA Phase 31 Preliminary project
- SIA Phase 32 Construction project
- SIA Phase 41 Tendering and comparison of offers
- SIA Phase 51 Execution project
- SIA Phase 52 Execution
- Statics and construction
- Specialist fire protection planning
- Work planning 3D and 2D
- Product development

### Client

Allianz Suisse  
8010 Zurich

### Architect

weberbrunner architekten ag  
8045 Zurich

### Architect

Soppelsa Architekten GmbH  
8047 Zurich

### Timber construction engineer

Timbatec Holzbauingenieure (Schweiz) AG Zurich  
8005 Zurich

### GU/TU

Implenia Schweiz AG  
8305 Dietlikon